



INSERTO Ø18



Ø	H	SPES
18	13	16
18	14,2	18/9
18	17	23

MATERIALE: *PLASTICA*
FINITURA: *BIANCO*

STAFFA ANCHOR II



L1	L2	i	SPES
22	20	8	16
22	20	9	18/19
22	20	11,5	23

MATERIALE: *ZAMA*
FINITURA: *ZINCATO NICHELATO NERO; NICHELATO*

EUROVITE

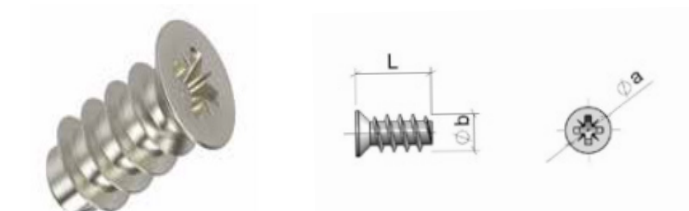

Ø	Øa	Øb	L
5	7,8	6,3	11
5	7,8	6,3	13
3	7,8	4	11

MATERIALE: *FERRO*
FINITURA: *ZINCATO; ZINCATO NICHEL NERO; NICHELATO*

STAFFA ANCHOR II CON BUSSOLA

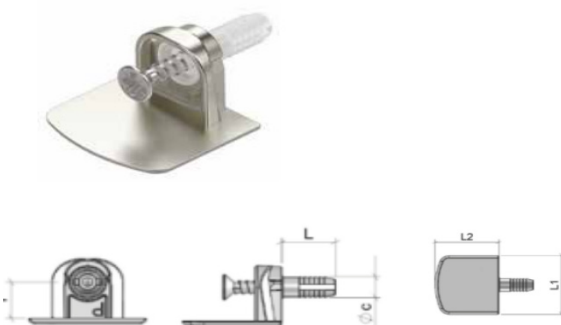

Ø	Øa	L	L1	L2	i	SPES
5	4,8	10,5	22	20	8	16

MATERIALE: *ZAMA*
FINITURA: *NICHELATO*