

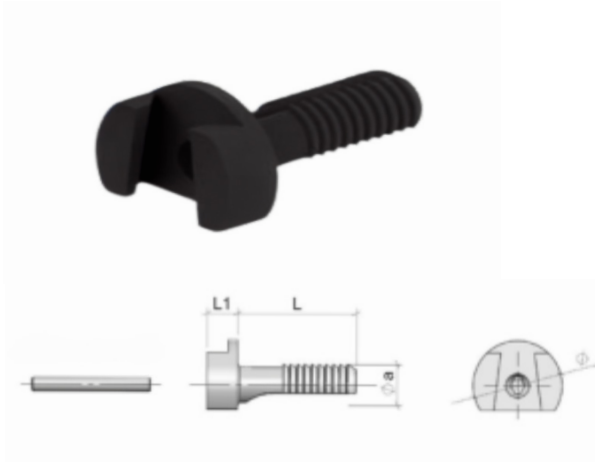

## SUPPORTO AD ESPANSIONE Ø21



Ø	Øa	Øb	L	L1	P	P1	i	SPES
21	9	9	33	7	7,2	23	7,5	25

MATERIALE: *PLASTICA*  
FINITURA: *NERO*

## STAFFA CON FORO SVASATO

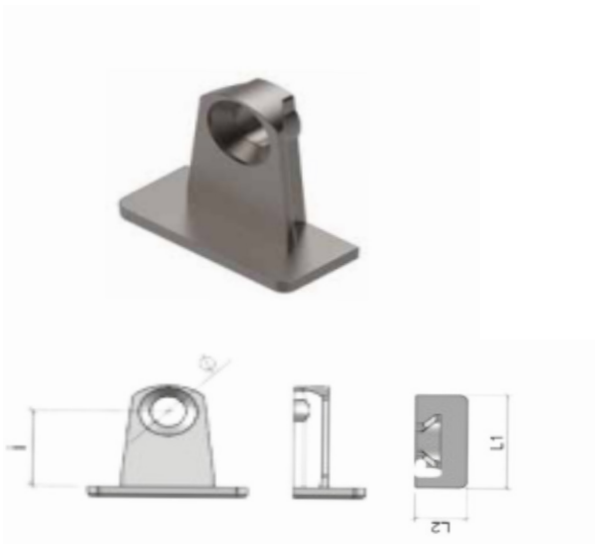

Ø	L1	L2	i	SPES
5	22	10	12,5	25

MATERIALE: *ZAMA*  
FINITURA: *NICHELATO; ZINCATO NICHELATO NERO*



## STAFFA CON FORO AUTOFILETTANTE



$\emptyset$	L1	L2	i	SPES
3,7	22	10	12,5	25

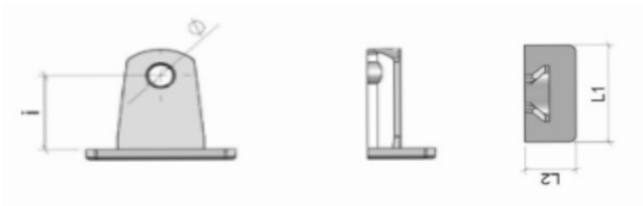

MATERIALE: ZAMA  
FINITURA: NICHELATO, ZINATO NICHELATO NERO

## VITE DI FISSAGGIO



L	M
12	M4
8	M4

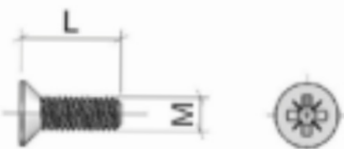

MATERIALE: FERRO  
FINITURA: ZINCATO; NERO