



BARILOTTO Ø14 CON BORDO



Ø	Øa	H	M	i	SPES
14	16	13	M8	8	16
14	16	14	M8	9	18
14	16	15	M8	10	20
14	16	16	M8	11	22
14	16	17,5	M8	12,5	25
14	16	13	M8XI	8	16
14	16	14	M8XI	9	18

MATERIALE: ZAMA

FINITURA: GREZZO - ZINCATO - ZINCATO NICHEL NERO - BRONZATO

BARILOTTO Ø14 SENZA BORDO



Ø	H	M	i	SPES
14	13	M8	8	16
14	14	M8	9	18
14	15	M8	10	20
14	16	M8	11	22
14	17,5	M8	12,5	25
14	13	M8XI	8	16
14	14	M8XI	9	18

MATERIALE: ZAMA

FINITURA: GREZZO - ZINCATO - ZINCATO NICHEL NERO - BRONZATO



BARILOTTO Ø12/14

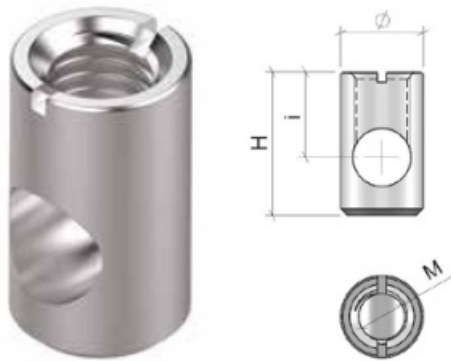

Ø	H	M	i	SPES
12	14	M8	9	18
12	21	M8	12,5	25
14	17	M8	10	20

MATERIALE: FERRO
FINITURA: GREZZO - ZINCATO - ZINCATO NICHEL NERO

TIRANTE Ø7/8

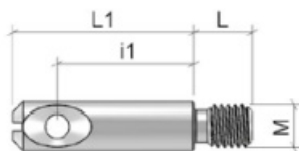

Ø	L	L1	M	i1
7	8,5	25	M6	18,5
7	8,5	26,5	M6	20
7	8,5	35	M6	28,5
7	8,5	36,5	M6	30
7	8,5	26,5	6 euro	20
7	8,5	33,5	6 euro	27
8	8,5	35,5	M8	20
8	8,5	36,5	M6	21

MATERIALE: FERRO
FINITURA: ZINCATO



GRANO M8

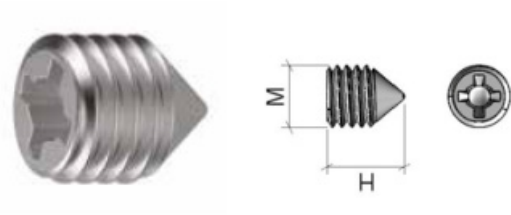

H	M
8	M8
10	M8
10	M8x1
12	M8x1

GRANO M8 PLUS

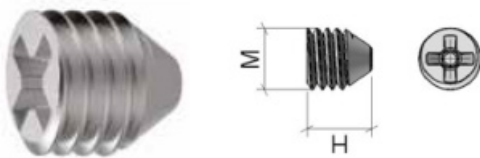

H	M
8,2	M8
12	M8

MATERIALE: ZAMA
FINITURA: GREZZO - ZINCATO - ZINCATO NICHEL NERO



COPRIFORO Ø14



\varnothing	$\varnothing a$	H
14	16	3

MATERIALE: *PLASTICA*
FINITURA: *BIANCO; NERO; MARRONE*

COPRIFORO Ø14



\varnothing	$\varnothing a$	H	H1
3,4	17	1,2	5

MATERIALE: *PLASTICA*
FINITURA: *ACERO*



VITE RULLATA

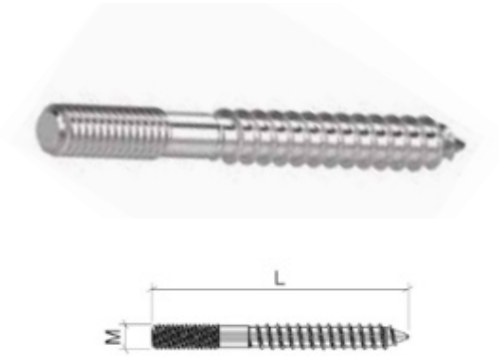

L	M
40	M4

MATERIALE: *PLASTICA*
FINITURA: *BIANCO; NERO; MARRONE*

TIRANTE PER VITE RULLATA



Ø	L	M	i1
8	37	M4	30

MATERIALE: *FERRO*
FINITURA: *ZINCATO*



TIRANTE DOPPIO



Ø	L	i1
7	62	42
6	62	42
7	56	42
7	52	37

MATERIALE: FERRO
FINITURA: ZINCATO

TIRANTE DOPPIO AD ANGOLO Ø7



Ø	L	i1
7	45	39,5

MATERIALE: FERRO
FINITURA: ZINCATO